

photomultiplier HV Base

HVSW12AN series data sheet

1 description

The HVSW12AN is a compact power efficient photomultiplier negative polarity HV Base operating from a low voltage supply (+5 to +15 V). It incorporates a negative HV supply and an active MOSFET voltage divider. The HV Base is intended for use with most 9-stage, 30 mm side window photomultipliers for applications requiring up to -1250 volts and ac or dc coupling.

The unit is housed in a screened cylindrical metal enclosure with threaded mounting bushes. The anode output is via a 0.5 m length of shielded RG174U cable and can be ac or dc coupled.

The photomultiplier operating voltage is set by using any one of three programming options as shown in section 8. The anode is at ground potential in the HVSW12AN .

2 applications

The HVSW12AN is designed for use in the following operating modes:

- current measurement (analogue)
- pulsed light
- photon counting

3 features

- compact
- no high voltage cables
- low noise
- linearity limited only by photomultiplier performance
- low power consumption

4 specifications

at HV = 1000V	unit	min	typ	max
supply voltage	V	+5		+15
control voltage	V	+0.1		+1.25
output high voltage	V	-100		-1250
output (anode) current	μA			100*
supply current at +5 V; for anode current = 0 μA	mA		70	
for anode current = 100 μA	mA		150	
supply current at +12 V: for anode current = 0 μA	mA		40	
for anode current = 100 μA	mA		60	
line regulation	%/V			0.01
anode load regulation: for anode current 0 - 100 μA	%			0.01
temperature coefficient	%/°C			0.02
switch-on time (10 - 90%)	s		0.2	
switch-off time (90 - 10%)	s		3	
anode ripple: for anode load = 10 kΩ 22pF	mV(p-p)		1	
weight	g		60	

*subject to photomultiplier limit



5 ratings

	unit	min	typ	max
supply voltage	V	4.5		18
control voltage	V	0		1.5
temperature (operating): at 93% RH, non-condensing	°C	-40		60

6 schematic diagram

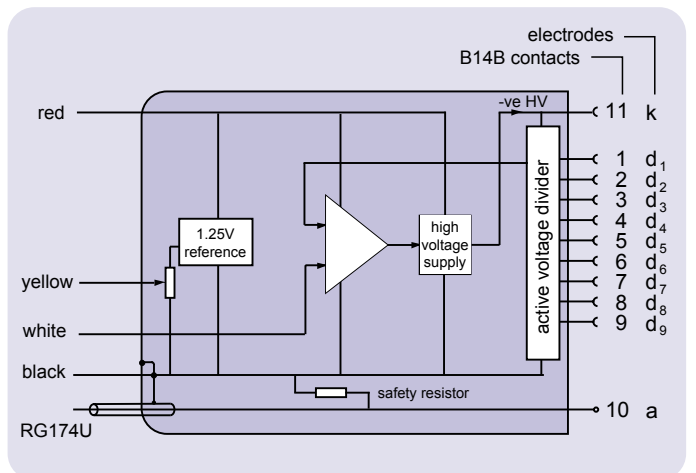

7 voltage distribution

The photomultiplier pin configuration for this HV Base is given below. The voltage distribution for an applied HV of V volts is shown in the table. An anode load resistor is not included but a 10 MΩ safety resistor is connected between anode and ground to ensure that the output is kept at 0 V.

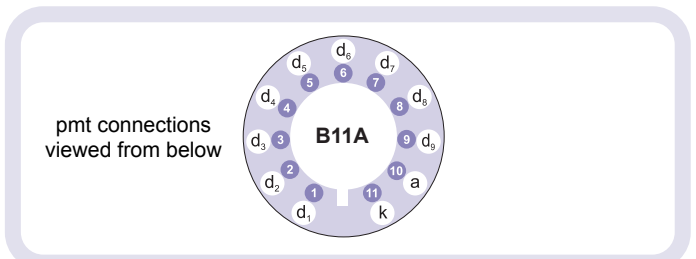

k	d ₁	d ₂	d ₈	d ₉	a
1/10V	1/10V	1/10V	1/10V	

8 programming options

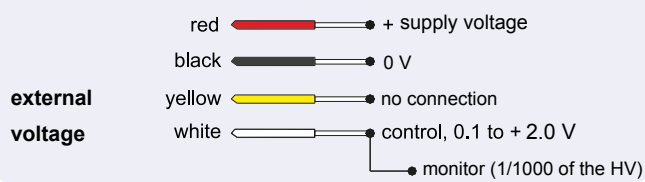
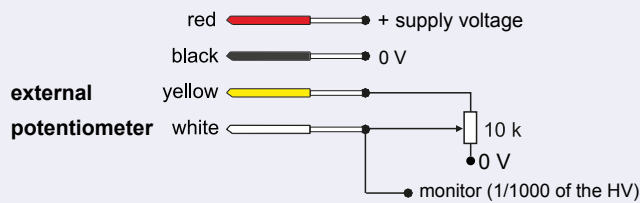
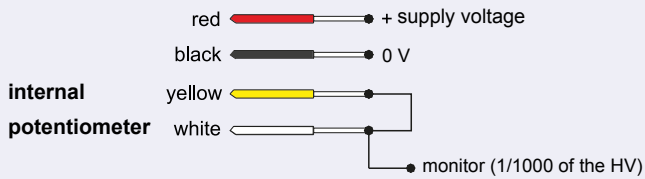

9 dimensions and photomultiplier options

The HVSW12AN HV Base can be used with the following photomultipliers:

9780B, 9781B, 9783B and all other 29 mm side-window photomultipliers

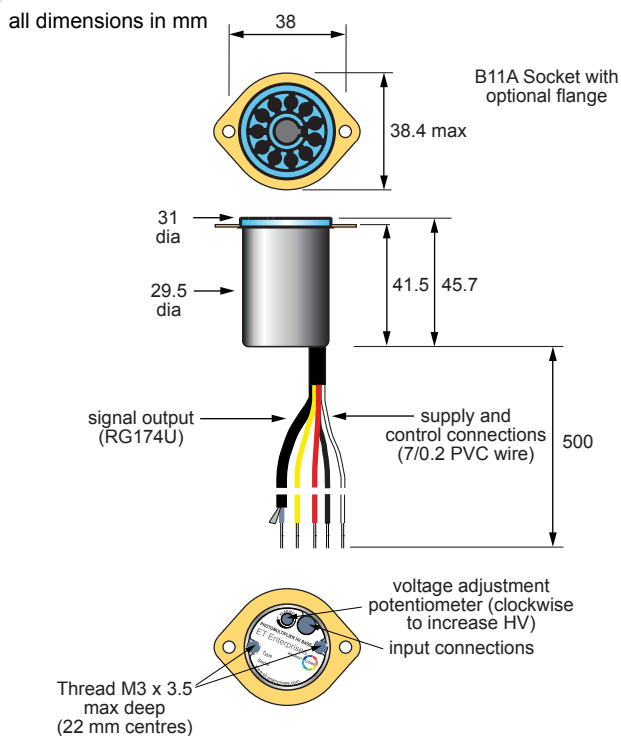

10 linearity

Linearity performance is dependent on the particular photomultiplier being used with the HV Base. It is measured as the % deviation in either peak pulse current, or average current, depending on the mode of operation.

Please refer to the corresponding photomultiplier data sheet for further information.

11 output configuration

The pmt anode in the HVSW12AN HV Base is internally grounded via a 10 MΩ safety resistor. Depending on the mode of operation, the output circuitry should be configured externally as shown in the example configurations below. For dc and scintillation applications R_L is typically 100 kΩ, but for fast pulse applications R_L would normally be 50 Ω. In the latter case an internal 50 Ω matching resistor can be fitted (to special order).

a) dc current output

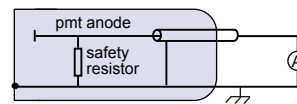

b) dc voltage output

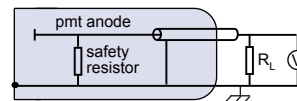

c) ac coupled output

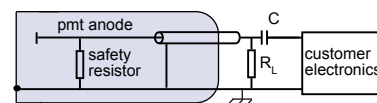

C = external coupling capacitor
 R_L = external load resistor

12 ordering information

item	ordering code
without flange	HVSW12AN
with flange	HVSW12ANF

13 warning

High voltages generated by these products present an electrical shock hazard and appropriate precautions must be taken.

Installation must be by qualified personnel.

All units are despatched with the internal potentiometer set to zero.

Do not operate outside the quoted ratings of the HVSW12AN or those of the photomultiplier. This may result in loss of performance, permanent damage, or both.